

A Design of Jet Mixed Tank

K. L. Wasewar

Department of Chemical Engineering, Birla Institute of Technology and Science, (BITS), Pilani, Rajasthan – 333031, India
Tel: + 91-1596-245073 ext 215; Fax: + 91-1596-244183;
Email: k_wasewar@rediffmail.com, kwasewar@bits-pilani.ac.in

Original scientific paper
Received: April 25, 2005
Accepted: December 12, 2005

Jet mixing has become alternative to conventional impeller mixing for various applications in process industries. Mixing time is an important design parameter in jet mixing. Many authors have used different parameters like jet velocity, jet diameter, tank height etc. to find out the correlation for mixing time. There is no comprehensive review, which tells exclusively about these parameters used for jet mixing. Recently many authors have used CFD in order to overcome experimental limitations for design of jet mixed tanks. A critical analysis of the available literature data has been made and some general conclusions have been drawn concerning the various parameters. This review focuses on the study of various parameters used in experimental and CFD work on jet mixed tanks to get the optimum design procedure.

Key words:

Jet mixing, mixing time, experimental, CFD, parameters, design

Introduction

Mixing is one of the common unit operation employed in chemical industries. It is used for blending of liquids, homogenization of mixtures, to ensure proper heat and mass transfer in various operations, prevention of deposition of solid particles etc. Impellers are the conventional devices used for mixing purpose in industries. But they are very expensive for large storage tanks and underground tanks. Jet mixers have become alternative to impellers for over 50 years in the process industry.

In jet mixing, a part of liquid from the tank is circulated into the tank at high velocities with the help of pump through nozzles. The resulting jet of fluid entrains some of the surrounding fluid and creates a circulatory pattern, which leads to mixing in the tank. This mixing can be properly explained as follows:

1. Bulk transport of jet liquid from the jet nozzle to remote areas of the tank.
2. Bulk transport, induced by jet flow in remote areas of the tank.
3. Bulk transport, induced by entrainment of secondary liquid into the jet
4. Mixing of the jet and secondary liquids (may be the same liquid) within the jet flow.

Jet mixers have several advantages over conventional impellers. It has no moving parts as in conventional agitators. So maintenance costs are low. It is cost effective for liquids and slurries having viscosities (below $1 \text{ kg m}^{-1} \text{ s}^{-1}$, 1000 cP) and larger volumes ($>300 \text{ m}^3$). Jet mixers are easy to in-

stall when compared with impellers. Agitator requires support at the top of the tank, which may mean specifying thicker walls of stronger materials. Jet mixing leaves fewer dead spots in a shallow or rectangular tank than does agitators. If system needs shear besides mixing, then jet mixer is more efficient. Bathija¹ reported that jet mixer uses 20–40 % less energy than off bottom solids suspension and for gas/liquid contacting. Mechanical agitators show disadvantages at industrial scale, as regards investment and energy costs, and also for sterilization and maintenance in biochemical processes. Jet mixers are preferable in these situations. Industrial applications of tank jet mixing have ranged from the homogenization of hydrocarbon and LNG storage tanks^{8,9,57} to acid mixing.⁵⁸ Jet mixer is used for blending the inhibitor into the monomer storage tank to stop violent run away of exothermic polymerization reactions,^{12,24} for emergency cooling systems of chemical reactors in case of break down in operation,³³ biochemical applications,³⁵ in fast competitive consecutive reactions having a mixing sensitive product distribution.¹

There have been many extensive studies on jet mixing for over 50 years. Number of experimental correlations is available. So there is a dilemma in using correct experimental correlation from all those correlations. So there is need to know the limitation of each correlation before using it in the design of jet mixing process. So far there is no comprehensive review, which can explain different authors' works on same parameters. So here different parameters have been identified, work done by au-

thors on each parameter, and explained. It is natural to overcome many contradictions in any research process. An attempt is made to review critically the contradictions on jet mixing process. Recently computational fluid dynamics is being used to overcome certain limitations of experimental studies. Good amount of work has been done on jet mixing with the help of computational fluid dynamics (CFD). It has been reported in the literature that good scope exists for design of jet mixing effectively in the future with the help of CFD modeling. Considering all these reasons, it is felt that review is needed for jet mixing process.

In the present paper, a critical analysis of the available literature data has been made and some general conclusions have been drawn concerning the various parameters. This review focuses on the study of various parameters used in experimental and CFD work on jet mixed tanks to get the optimum design procedure.

Jet flow behavior

Turbulent jet

Turbulent jet flow can be divided into two distinct regions, the core region and the fully developed region as shown in Figure 1. In the core region or flow development region, there exists a cone like volume of jet liquid of velocity v_j . This cone of the liquid is known as potential core. There is no change in velocity in this region. In the fully developed region, which starts at about 10 times d_j , jet diameter from the nozzle, centerline jet velocity v_m continuously decreases with the distance from the jet in the direction of jet flow. Similarly centerline concentration also decreases with the distance

from the jet in the direction of jet flow. As the jet penetrates the bulk liquid, it entrains bulk liquid and expands at jet angle. Jet angle is difficult to measure, however, it is reported in the literature as varying between 15° and 25° for jet Reynolds number $Re_j > 100$. Donald and Singer⁷ have done extensive work on jet angle and length of potential core. Similarly the volumetric flow rate of the bulk liquid entrained by the jet Q_e is difficult to measure and the available experimental data are widely scattered. There have been a large number of studies of the behavior of turbulent jets (e. g. Abramovich,⁵⁹ Rajaratnam⁶⁰).

Flow patterns

Flow patterns can be represented by the velocities at all places in the flow domain. Poor velocity distribution is responsible for the unmixed regions. In this way flow patterns identify mixed and unmixed regions and gives the idea where exactly mixing should be improved by improving velocity distribution. Concentration will be same or nearer as mean concentration at well-mixed regions. Velocity will be very less at poor mixed region when compared to velocity at well-mixed regions. Physically, circulation patterns are more in well mixed region i.e. due to high velocity and very less or sometimes stagnant at low mixing regions. So far in the literature various types of jets, side entry jets, axial jets, jets from the top surface and jets from the bottom, have been used. Fox and Gex¹¹ have reported that position of the jet changes the last part of the liquid to be mixed. Revill^{32,71} reported flow patterns in side entry jets and axial jets as shown in the Figures 2(a), 2(b), 2(c), and 2(d). Poorly mixed regions i.e. dead regions are shown clearly in the figures. Figures 2(a) and 2(b) represent flow pat-

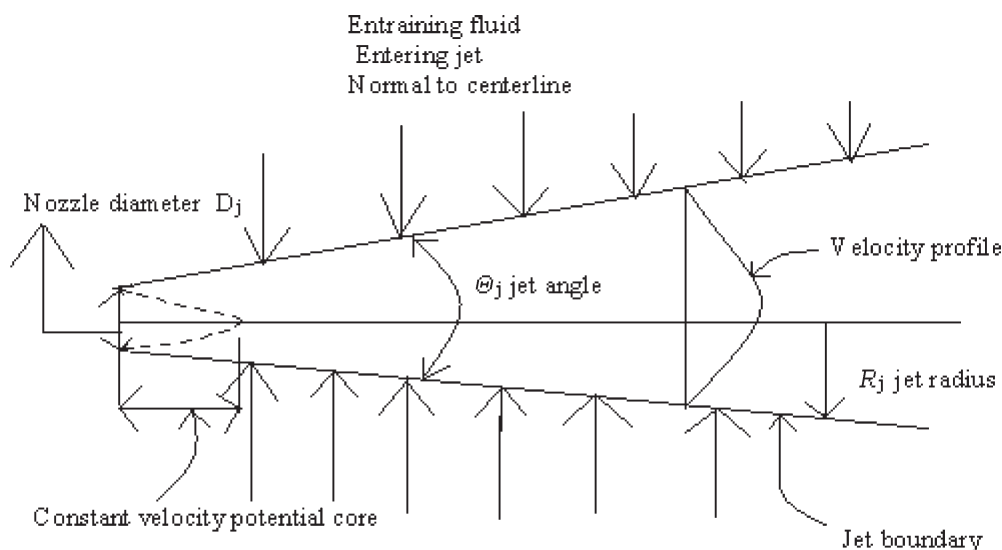

Fig. 1 – Turbulent free jet

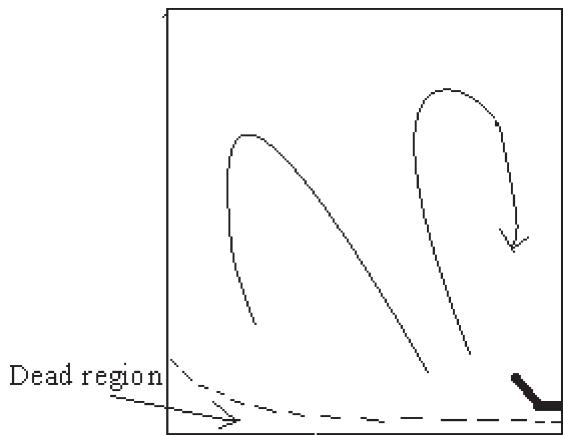

Fig. 2 a – Upward pointing side entry jet

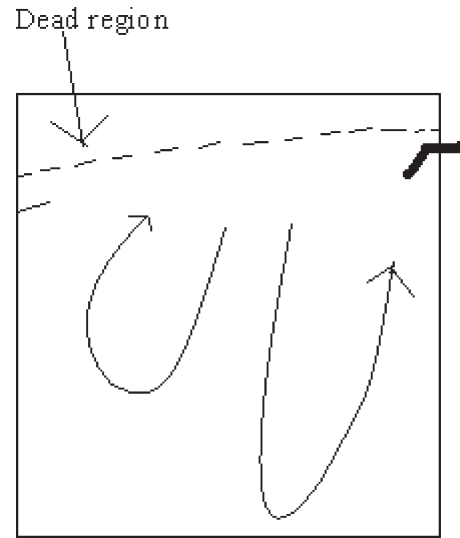

Fig. 2 b – Downward pointing side entry jet

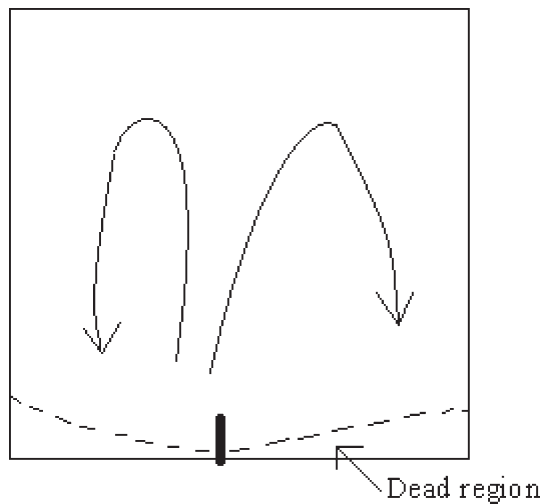

Fig. 2 c – Upward pointing vertical jet

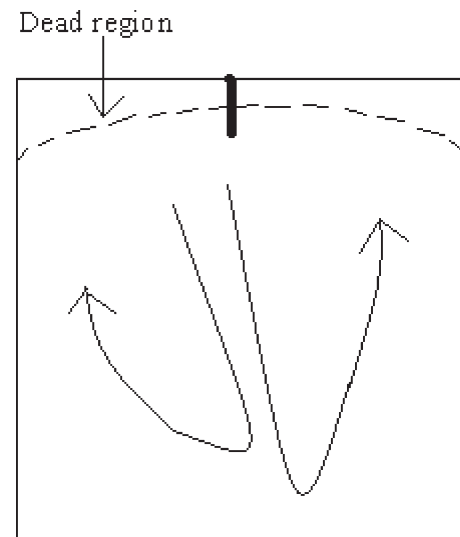

Fig. 2 d – Downward pointing vertical jet

terns for side entry jets. Figures 2(c) and 2(d) represent flow patterns for vertical axial jets. Wood et al.⁵⁴ investigated the flow field created by two impinging liquid jets in a cylindrical chamber. Cziesla et al.,⁵⁵ Gao and Voke⁵⁶ and Voke and Gao³⁷ simulated jets impinging on a wall using large eddy simulation (LES) technique.

Correlations

Schlichting³⁴ gave an analytical equation for the radial distribution of the axial velocity for the free turbulent jet.

$$v = \frac{3}{8\pi} \frac{K}{v_0 z} \frac{1}{\left[1 + \frac{1}{4}\eta^2\right]} \tag{1}$$

where

$$\eta = \frac{1}{4} \sqrt{\frac{3}{\pi}} \frac{K^{\frac{1}{2}} r}{v_0 z}, \quad K^{\frac{1}{2}} = 1.59 b_1 v_C, \quad v_0 = 0.256 b_1 v_m,$$

$$b_1 = 0.0848 z, \quad v_m = 7.31 \frac{d_j v_j}{z}$$

Davies⁶ has formulated an equation to find the centerline velocity for a free turbulent jet. The equation is

$$v_m = 6.4 \frac{d_j v_j}{z} \tag{2}$$

Where z is the distance from the nozzle axis in the direction of jet flow.

For free turbulent jet, Davies⁶ has given the radial distribution of the axial velocity approximated by a curve of normal error with the following equation

$$\log_{10} \left[\frac{v}{v_j} \right] = 40 \left[\frac{r}{z} \right]^2 \quad \text{for} \left(7 < \frac{z}{d_j} < 100 \right) \quad (3)$$

Where r is the perpendicular distance to the direction of the jet.

Revill^{32,71} reports the equation for axial velocity in fully developed region of turbulent jets, which is as follows

$$\frac{v_m}{v_j} = 6 \frac{d_j}{z} \quad (4)$$

Where z is the distance from the jet, j refers to the jet, v refers to the velocity.

From above equation, it is observed that center line jet velocity falls to about 5 % of the initial values after an axial distance of 100 jet diameters. After 400 jet diameters the velocities become so low that the mixing effect of the jet is insignificant at more remote positions.

Revill³² reported equation for centerline concentration c_m as follows

$$\frac{c_m}{c_j} = \frac{4.5 d_j}{z} \quad (5)$$

From above equation, it can be observed that centerline concentration falls to about 5 % of the initial values after an axial distance of 100 jet diameters.

Folsom and Ferguson¹¹ investigated jet mixing of two liquids of same density. It was found, that mixing outside of the turbulent jet in the bulk of the recirculating liquid, was negligible. The amount of the liquid entrained increased with the distance as the ratio of entrained fluid, divided by the power input, was used as a measure of the performance. The radius of the expanding jet as shown in the Figure 1 was found to be, $R_j = 0.232 z$. The amount of liquid entrained was:

$$Q_e = \left[0.234 \left(\frac{z}{d_j} \right) - 1 \right] Q_0 \quad (6)$$

Where Q_0 is the volumetric flow rate at the jet start.

According to Donald and Singer,⁷ the total volumetric flow rate in the jets was correlated as

$$Q_T = Q_0 \left[\frac{0.576 v^{0.133} z}{d_j} \right] \quad (7)$$

Where Q_0 is the discharge flow rate of the jet, Q_T is the total flow in the jet at the distance z from the nozzle,

Mixing time

Mixing time is an important design parameter in jet mixing. Many experiments have been conducted in the literature to determine mixing time. In this section, various methods for mixing time determination and experimental correlations are explained.

Measurements of mixing time

Many literatures are available on the measurement of mixing time in jet mixed tanks. Broadly measurement techniques can be classified in two types, such as tracer techniques and visual observation techniques.

In tracer techniques, the tracer is usually injected into the tank. The tracer concentration is then measured with respect to time at a point or various positions in the tank using conductivity probe. The mixing time is taken as the time at which the tracer concentration, c , at the measurement location has reached or nearly reached, the expected final mean tracer concentration. Mathematically the mixing time can be defined as the time from tracer addition to the time when $\frac{|c - \bar{c}|}{\bar{c}} = m$, where m is the maximum acceptable value for deviation from mixing. When just the process of mixing starts, $m = 1$, when complete mixing is achieved $m = 0$, but in most of the case $m = 0.05$ is considered i.e., mixing time required to achieve 95 % mixing.

In the visual observation technique, the tank liquid is first made weakly acidic and an indicator is added. Strong base in a quantity just sufficient to neutralize the acid is then added. The mixing time is taken as the time from the moment of base addition to the time at which color of the indicator disappears.

Fossett and Prosser⁸ injected a small amount of the solution of the sodium carbonate into the recirculation loop of the tank and determined the degree of mixing using a pair of electrodes immersed in a tank at the centers where circulation pattern occurred. The total mixing time was that at which there was zero reading on a galvanometer, connected to the electrodes, due to uniform concentration in the tank. Fox and Gex¹¹ used visual determination technique for determination of mixing time. Sodium hydroxide solution and phenolphthalein indicator was added to the tank contents. Then an exact amount of neutralizing acid was added instantaneously. The time taken for the indicator color to change was taken as mixing time. Van de Vusse³⁹ measured mixing as the time at which densities of the sample drawn were within few percent of the expected mean density. Okita and Oyama²⁵

injected a pulse at the centre of the tank near the liquid surface. They defined mixing time as the time between tracer addition and the moment at which there were no differences in concentration measured by two probes, one located at the liquid surface and one located at the bottom of the tank floor. *Lane and Rice*^{19,21,68–70} and *Rice*⁶⁷ measured mixing time at the point where it was longest through out the tank. They used conductivity technique. The output of the each mixing run was traced with the chart recorder. They defined mixing time as the time from the start of pulsed salt injection to the time when concentration was firstly consistent within 5 % of the final and steady state concentration. *Maruyama et al.*^{23,65,66} and *Yianneskis*⁴² used conductivity technique with the help of tracer. Later on some people have started measuring concentration at many locations for more accuracy. *Simon and Fonade*³⁵ gave a pulse of electrolyte solution through pump discharge and conductivity was monitored at eight locations to measure mixing time. *Perona et al.*²⁹ and *Patwardhan*²⁷ monitored conductivity at four locations to measure mixing time. *Fackler*⁶² investigated jet mixing in a cylindrical tank with a tangential jet inlet and an axial outlet. The jet Reynolds number was above a critical value (near 2100). Mixing times were determined as a function of inlet jet height to liquid height ratio; the height to diameter ratio, of the tank and the nature of the velocity field. *Fackler*⁶² identified two major circulation zones in the tank at 0.5 of inlet jet height to liquid height ratio; one in the top and the other in the bottom which mixed only at the jet height. This compartmentalization extended the mixing times. *Hiraoka et al.*⁶³ studied circulation and mixing times for jet mixing in tanks and correlated mixing time with jet flow rate, number of jet nozzles, and liquid depth. *Coker and Jeffreys*⁶⁴ have studied mixing of a tracer by tangential jets in a large cone-bottom tank One of the main reasons for obtaining different correlations is the use of different type of techniques for measuring concentration. It is always better to use more conductivity probes at corners rather than the middle part of the tank.

Mixing time correlations

In the past, many experimental studies have been carried out on jet mixing. *Fossett and Prosser*⁸ investigated jet mixer performance using a laboratory scale model. Inclined side entry jet was used as shown in Figure 3 for jet mixing studies. A wide range of jet Reynolds number, 4500 to 80 000 were used and reported, that mixing by simple jets would occur in a time much stronger than is usually taken by conventional mixing devices. Based on their measurements for single jet, it was proposed the following correlation for the mixing time.

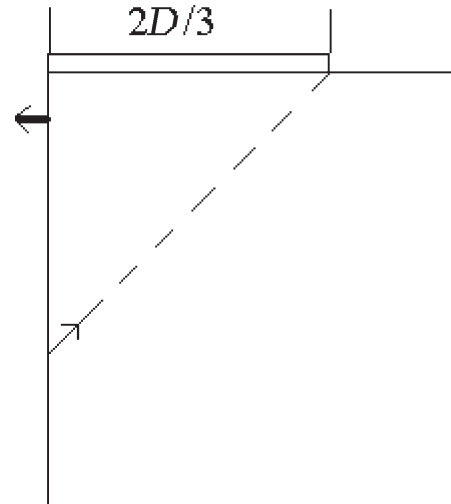

Fig. 3 – *Fossett and Prosser*⁸ geometry

$$t_{\text{mix}} = 9 \frac{D^2}{v_j d_j} \quad (8)$$

The injection of the tracer occupied a considerable proportion of this measured total mixing time and the tank contents were usually 50–90 % homogenous before injection was complete. This was emphasized in their paper and *Fossett*⁹ later proposed that for a short pulse injection a more appropriate correlation would be

$$t_{\text{mix}} = 4.5 \frac{D^2}{v_j d_j}, \quad (9)$$

The two equations can be combined as

$$t_{\text{mix}} = C_p \frac{D^2}{v_j d_j} \quad (10)$$

$$C_p = 9, \text{ when } t_{\text{inj}} > t_{\text{mix}}/2,$$

$$C_p = 4.5, \text{ when } t_{\text{inj}} < t_{\text{mix}}/2$$

$$t_{\text{inj}} = \text{time of injection.}$$

Because of obvious difficulty in interpreting the measured mixing time and many variables, such as tank height, H and kinematic viscosity ν constant and only varied jet diameter, d_j and jet velocity, v_j , this work is of limited use. *Fox and Gex*¹¹ extended the investigation to both laminar and turbulent regimes and also did the comparative studies of mixing using a jet and a propeller. It was found, that the most important parameter that determined the mixing time, was the momentum flux added to the tank. It was studied over a range of parameter, and observed a clear effect on the jet Reynolds number on

the mixing time, except at very high Reynolds number, and presented a correlation for the mixing time.

$$t_{\text{mix}} = f \frac{(H^{0.5} D)}{(v_j d_j)^6 g^{\frac{1}{6}}} \quad (11)$$

Racz and Wassink⁶¹ used the tracer technique to measure mixing time and proposed the correlation for 95 % mixing,

$$t_{\text{mix}} = 3.9 \frac{D^2}{v_j d_j} \quad (12)$$

Okita and Oyama²⁵ based on their results concluded that mixing time does not depend on Reynolds number ($Re_j > 5000$) in turbulent regime. Coldrey⁴ used geometry as shown in Figure 4 and reported that longer jet length gives shorter mixing time. Assuming that mixing time is inversely proportional to the amount of liquid entrained by the jet, an equation was proposed for mixing time. Hiby and Modigell¹⁶ who used vertical jet as shown in

Figure 5, reported that mixing time is dependent on jet Reynolds number. Lehrer²⁰ formulated a model for free turbulent jet of miscible fluids of different density in which lateral transfer of momentum was considered to be due to eddy diffusion. Lane and Rice^{19,21,68–70} and Rice⁶⁷ used cylindrical tank with hemispherical base as shown in Figure 6, and proposed a correlation showing strong dependence on jet Reynolds number in the laminar regime, but weak function in turbulent regime. Maruyama et al.^{23,65,66} also proposed a correlation for mixing time. Yianneskis⁴² reported on mixing time dependence on power consumption. Simon and Fonade³⁵ Orfanotiis et al.²⁶ used geometry, as shown in Figure 7, and proposed correlations for steady and unsteady jets. Grenville and Tilton¹⁴ proposed that mixing time was controlled by the turbulent kinetic energy dissipation rate in the region away from the jet entrance. Grenville and Tilton¹⁵ reported that mixing time was proportional to the circulation time (estimated from the volume of liquid in the tank and flow rate entrained by the jet). All these correlations are summarized in Table 1.

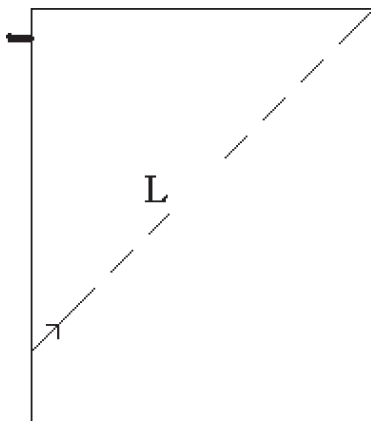

Fig. 4 – Coldrey⁴ geometry

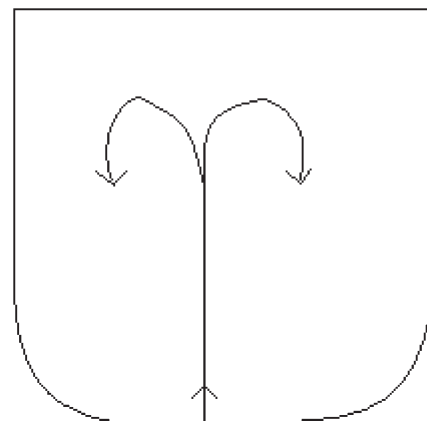

Fig. 6 – Lane and Rice¹⁹ geometry

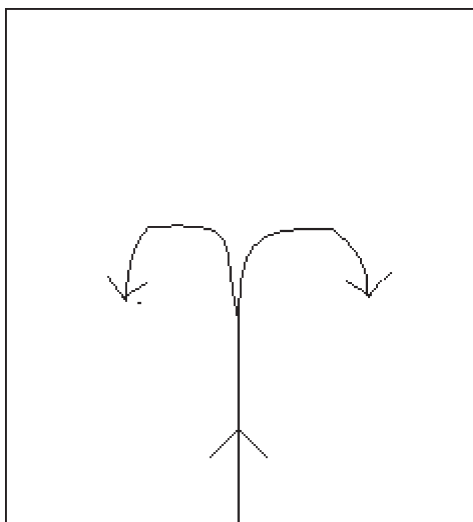

Fig. 5 – Hiby and Modigell¹⁶ geometry

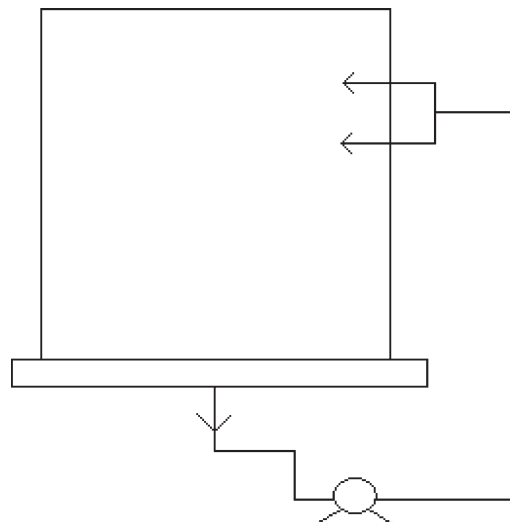

Fig. 7 – Simon and Fonade³⁵ geometry

Table 1 – Experimental correlations of jet mixing in tanks

Author	Geometry or jet configuration	Dimensions	Correlation	Remarks
<i>Fossett</i> ⁹	Inclined side entry jet and cylindrical tank	$D = 1.524$ m $H = 0.9144$ m $d_j = 1.9$ mm $d_0 = 2.54$ cm, $\Theta = 40^\circ$	$t_{\text{mix}} = C_p \frac{D^2}{v_j d_j}$ $C_p = 9$, when $t_{\text{inj}} > t_{\text{mix}}/2$, $C_p = 4.5$, when $t_{\text{inj}} < t_{\text{mix}}/2$	Does not relate mixing time to height of liquid. So not reliable when height changes or when it is different from <i>Fossett</i> ⁹ experiment
<i>Fox and Gex</i> ¹¹	Side entry jet Cylindrical tank	$D = 0.29$ & 1.52 m	$t_{\text{mix}} = f \frac{(H^{0.5} D)}{(v_j d_j)^{\frac{4}{6}} g^{\frac{1}{6}}}$	Did not specify the exact criteria for degree of mixing as per <i>Lane and Rice</i> . ¹⁹ So accurate results may not be obtained
<i>Lehrer</i> ²⁰	–	–	$t_{\text{mix}} = \frac{0.658}{v_j} \left(\frac{\rho_c}{\rho_d} \right)^{\frac{5}{8}} d_j^{0.25}$ $\times \left(\frac{v_j}{N_j A} \right)^{\frac{3}{4}} (-\log(1 - c^*))$	Developed a model and compared results with that of <i>Fox</i> and <i>Gex</i> . ¹¹
<i>Lane and Rice</i> ¹⁹	Side entry and axial jets and cylindrical tank	For side entry jets $D = 0.31$ – 0.57 m $H/D = 0.9$ – 1.1 m For axial jets $D = 0.31$ – 0.57 m $H/D = 0.5$ – 3.0 m $Re_j = 250$ – $60,000$	$t_{\text{mix}} = f \frac{(H^{0.5} D)}{(v_j d_j)^{0.667} g^{0.166}}$	Applicability outside Recommended design height is not accurate
<i>Maruyama et al.</i> ²³	Side entry jets. Cylindrical tank	$D = 56,104$ cm $H = 84, 125$ cm $h_p, h_o = 4,14,24,44,74,94$ ($D=104$ cm) $h_p, h_o = 4.38, 20.5, 48.5$ cm, ($D = 56$ cm) $d_j = 0.5, 1, 1.8$ $\theta = 7, 15, 30, 45, 54, 60, 73$	$\left(\frac{t_{\text{mix}}}{t_r} \right) \left(\frac{L}{d_j} \right) = 2.5 - 8.0$ $Re_j > 30,000$	Made recommendations for optimum nozzle depth in circulation flow regime.
<i>Simon and Fonade</i> ³⁵	Two jets at $H/2$ and $H/3$ horizontally located	$D, H = 490$ mm $d_j = 10$ mm	$M = t_{\text{mix}} (gH)^{0.5} D J_s^{\frac{2}{3}} \approx 1$ $J_s = \frac{J}{\rho v_j g}$, $J = \rho A v_j^2$	Only for steady and unsteady jets
<i>Orfaniotis et al.</i> ²⁶	Two jets at $H/2$ and $H/3$ horizontally located	$D, H = 500$ mm $d_j = 9, 15$ mm	$M = \left[\frac{v_{\text{mix}}}{t_r} \right] (J_s)^{0.41} = 11.3$ $t_r = \frac{D}{(gH)^{0.5}}$	Effect of viscosity on mixing time is studied
<i>Grenville and Tilton</i> ¹⁴	Cylindrical tank	$D = 0.61$ – 36 m $H/D = 0.2$ – 1.0 $d_j = 5.8$ – 50 mm $v_j = 2.2$ – 24.8 m	$t_{\text{mix}} = 3 \frac{L^2}{v_j d_j}$	Here effect of jet angle is not taken into account
<i>Grenville and Tilton</i> ¹⁵	Same as <i>Grenville and Tilton</i> ¹⁴	Same as <i>Grenville and Tilton</i> ¹⁴	$t_{\text{mix}} = k \frac{D^2 H}{v_j d_j L}$ $k = 9.34$, $\theta > 15^\circ$ $k = 13.8$, $\theta < 15^\circ$	Here effect of jet angle is considered. Reliable correlation according to <i>Patwardhan</i> ²²

For liquid mixing in jet mixed tanks, there are two areas of work: determining the optimum jet angle and then determining the mixing time at that time. At angles that are far from optimum the mixing time will be much longer and there can be stagnant areas, particularly, if the jet intersects the far wall far below the liquid surface. This has always been an area of confusing in using the correlations.

Parameters in jet mixing

Effect of tank height

From experimental correlations for mixing time, it can be observed that mixing time is directly proportional to tank height.^{4,11,15,19,21,25} So with increase in height of the tank, mixing time increases keeping other parameters constant.

Effect of tank diameter

From most of the experimental correlations, it is observed that mixing time increases with increase in diameter of the tank and vice versa for constant set of other parameters.

Effect of jet velocity

From all correlations given in Table 1, it is observed that mixing time decreases with increase in velocity, and increases with decrease in velocity, when all other parameters are kept constant. Precise relation between jet velocity and mixing time depends on the correlation used and parameters considered, as shown in Table 1.

Effect of jet diameter

Jet diameter appears almost in all experimental correlations of mixing time as given in Table 1. From most of the correlations it can be said that under same tank dimensions and jet velocity, mixing time is inversely proportional to jet diameter. But from *Coldrey*⁴ correlation, it is observed that under constant tank dimensions and at constant flow rate of jet, mixing time is directly proportional to jet diameter. After investigation of data of *Perona* et al.,²⁹ it is found that for the same flow rate, increase in jet diameter will only increase mixing time. From experimental results of *Gaikwad* and *Patwardhan*²⁸ at same power consumption level, increase in diameter will lead to decrease in mixing time.

Effect of location of jet

Mewes and *Renz*²⁴ and *Perona* et al.²⁹ found that the position of nozzle is one of the parameters affecting mixing process. *Maruyama* et al.^{23,65,66} ex-

tensively did experiments to find the optimum location of the nozzle in the circulation regime ($Re > 30\,000$). Optimum nozzle depth ranges from the liquid surface level to three quarters of the liquid depth, when the liquid depth is equal to the tank diameter and is the mid depth of the liquid, when the liquid depth is smaller than the tank diameter.

Effect of jet angle

*Fossett*⁹ used inclined jets for his investigation on jet mixing. *Okita* and *Oyama*²⁵ suggested in their work that the angle of the jet, relative to the base of the tank, does not affect mixing time. *Coldrey*⁴ and *Lane* and *Rice*^{19,21} in their experimental work propounded a theory that the configuration with the longest jet length, that is obtained when inclined at an angle 45° , gives shortest mixing time. According to *Maruyama et al.*,^{23,65,66} the mixing time has a local maximum at $\Theta = 0^\circ$ and local minimum in the range of $25\text{--}30^\circ$, a maximum in the range of $45\text{--}50^\circ$, again a local minimum at 75° , and finally a maximum at 90° . So according to them angle of 45° did not give shortest mixing time as propounded by *Coldrey*⁴. *Greenville* and *Tilton*¹⁵ also found that mixing time was increasing significantly when angle of injection at the base of tank is less than 15° due to the wall effect of jet. *Greenville* and *Tilton*¹⁵ propounded two correlations based on the angle of inclination of jet. This coincides with *Coldrey*⁴ but contradicts *Maruyama et al.*^{23,65,66} *Patwardhan*²⁷ also studied the effect of angle of jet on mixing time. *Gaikwad* and *Patwardhan*²⁸ reported that inclined jets at the bottom give better mixing times. It was found, that horizontal jets give larger mixing times than inclined jets at the bottom, and angle of 45° gives reduced mixing times than angles of 30° and 60° . *Greenville et al.*^{14,15} included the effect of angle of jet on mixing time and obtained correlation relating mixing time and angle of injection. Experiments were performed over a wide range of parameters. So this relation can be used to predict effect of jet angle on mixing time. Due to contradictions obtained in *Coldrey*⁴ and *Maruyama et al.*,^{23,65,66} some more experimental studies are to be done for finding the effect of jet angle at 45° .

Effect of tank geometry

Researchers have used various types of geometries, such as rectangular tanks, cylindrical tanks, to get better mixing times. *Lane* and *Rice*¹⁹ have reported shorter mixing times with a cylindrical tank, having a hemispherical base, than with a flat-based cylindrical tank for the same fluid. But hemispherical bottoms are not easy to fabricate and need constant supports. So in actual applications, cylindrical tank is being preferred.

Effect of multiple jets

*Fossett*⁹ has mentioned that multiple jets may give better mixing times but no experimental results were reported. *Perona et al.*²⁹ used number of jets as a parameter in finding mixing time in long horizontal cylindrical tanks. They found that double jets gave less mixing time when compared with single jet. *Simon and Fonade*³⁵ used alternating jets for biochemical application. They found that alternating jets perform better than steady jets. It can be concluded that not much experimental study has taken place on multiple jets and no particular experimental correlation is developed incorporating multiple jets.

Effect of jet configuration

Many experiments have been conducted with different configuration of jets such as inclined jets, vertical jets from the bottom or top of the liquid surface, downward pointing jet and upward pointing jet. Detailed description is given about inclined jets while describing effect of angle of jet. *Hiby and Modigell*¹⁶ used axial vertical jet for determining mixing time. *Revill*^{32,71} reported when to use downward pointing jet and upward pointing jet, axial jets and side entry jets. Position of the poorly mixed regions in the tank definitely depends on the jet configuration. If the best configuration, which can eliminate poorly mixed regions, mixing time can be reduced to a greater extent.

Effect of Reynolds number

Experimental correlations available in the literature can be broadly classified into two different groups i.e. relations showing dependence on Reynolds number and relations not showing dependence on Reynolds number, as given in Table 1. *Lee et al.*²¹ observed flow structures as a function of Reynolds number. However, the previous workers main interest was centered on specifying values of Reynolds number below which mixing is not effective. *Fox and Gex*¹¹ found that mixing time is a strong function of Reynolds number in the laminar regime and weak function in the turbulent regime. From the above experimental study of *Fox and Gex*,¹¹ it can be concluded that mixing is not effective above Reynolds number of 80 000. Further studies can be conducted in this direction. So this fact i.e. ranges of Jet Reynolds number should be taken into consideration while designing jet mixer.

Effect of density (Stratification)

When the liquids to be mixed have comparable different densities or $(\rho_2 - \rho_1)/\rho_2 > 0.05$ between the jet liquid and the bulk liquid and, if jet velocity

is less than critical velocity, then layers of high and low density liquids form, and mixing will not occur in that situation. This is called stratification. Here ρ_1 and ρ_2 are the densities of light and heavy liquids used, respectively. *Fossett and Prosser*⁸ have studied this phenomenon. They gave expression for critical velocity as

$$v_c = \left[\frac{2g Q_G E \left(\frac{\rho_2 - \rho_1}{\rho_2} \right)}{\sin^2 \Theta} \right]^{0.5} \quad (13)$$

Here Θ is the angle of inclination of the jet to horizontal plus 5° . ρ_1, ρ_2 are the densities of light fluid and heavy fluid, respectively, E is the excessive head developed. The above equation for v_c is based only on data for the injection of heavy liquid into a light liquid using an upward pointing jet.

*Fossett*⁹ has suggested on the intuition that if the jet liquid is lighter than the bulk liquid then a downward pointing jet should be used with a velocity of 1.5 times the v_c predicted by above equation. It is reported by *Revill*³² that this argument seems to be reasonable. *Coldrey*⁴ and *Revill*³² have questioned several aspects of the *Fossett and Prosser*⁸ work. They suggested that since no other data is available on this work, it is always better to exceed the critical velocity. It is usually accepted that a jet entrains liquid over a length of up to about $400 d_j$. One of the things found in *Fossett's*⁸ work was that he used tanks with length of the jet greater than $600 d_j$. Because of this, jet would not have influenced all parts of the tank. *Fossett*⁹ also mentioned about excess head concept required to prevent stratification.

Effect of viscosity

Different fluids can have different viscosities. Viscosity can affect mixing time. The more viscous fluids have more difficulties for mixing. So change in viscosity is to be considered while calculating mixing time. *Orfanotis et al.*²⁶ reported that mixing time increases with viscosity. Some more experimental studies are to be conducted, especially for non-Newtonian liquids, to see the effect of viscosity on mixing. Effect of viscosity is a pure transition Reynolds number effect. Below a certain Reynolds number one would expect an effect of viscosity but above it very little if any.

Effect of tracer injection

*Fossett*⁹ proposed two correlations as seen in Table 1, based on the injection time of tracer, one correlation for injection period occupying consider-

able portion of mixing time and another correlation for shorter pulse injection. *Yianneskis*⁴² also observed that mixing time increases almost linearly with tracer injection time. So to get good idea about mixing time, tracer injection time should be less.

Effect of outlet location

As pointed in *Fox* and *Gex*,¹¹ outlet is the place from where liquid is taken out from tank and sent to the nozzle. He also pointed out, that the outlet location should not be near the jet location or else feed from the jet is taken directly entering into suction of the outlet system. *Revill*³² also mentioned that poor mixed regions in the tank depend on the relative location of jet and outlet .

Effect of power consumption

*Yianneskis*⁴² proposed correlation relating mixing time and power consumption. The result indicated a straight line variation with a negative slope. It was observed that mixing time is proportional to specific power (power per unit mass), to the power of -0.33 i.e. $-1/3$.

Limitations of experimental studies

There is considerable amount of literature on jet mixing in tanks. However, the only information that is available is the overall mixing time for a given set of parameters. No data are available on the details of circulation and mixing patterns within the vessels.

– The basic limitation of correlations presented in Table 1 is that they predict well only over the range of parameters i.e. correlations are case specific.

– It can be seen that many correlations do not consider the liquid height as a parameter. This obviously cannot be true

– There is uncertainty in defining jet length

– Effects of properties such as density and viscosity of liquid and presence of solid particles on mixing time are reported only over a narrow range

– Available literature is concerned with liquid-liquid jet mixing and very few authors have considered solid sludge suspension using jet mixers.

The above discussion tells that the hydrodynamics of jet mixing is still not understood very well and that the large degree of empiricism and uncertainty is there in jet mixing.

Recommended jet/tank geometry

*Revill*³² has given the following recommendations for jet / tank geometry:

– Single axial jets only be used when the ratio of the tank height to diameter lies in the range

$$0.75 \leq \frac{H}{D} \leq 3 \quad (14)$$

– Single side entry jets should be used only when

$$0.25 \leq \frac{H}{D} \leq 1 \quad (15)$$

– Multiple side entry jets should be used only

$$\frac{H}{D} \leq 0.25 \text{ or if } \frac{H}{D} > 3.0 \quad (16)$$

Thus multiple jets should be used when designing a large diameter, shallow tank or a tall tank. In all the cases, the tank should be considered as a number of smaller tanks stacked either vertically or horizontally. Each of these tanks should be designed as a separate vessel

– Jet will lose its momentum when it hits the tank base or the wall, so it's better to position jet and be directed along the longest tank dimension. X should be no more than $400 d_j$. For side entry jets $X = \sqrt{(D^2 + H^2)}$, for axial jets $X = H$

This ensures the jet momentum is spread by entrainment and mixing the jet and bulk liquids. The object of any design should be to produce the liquid motion through out the whole tank.

– The jet nozzle should always be submerged during the actual mixing operation

– Side entry jets should be installed along a radius to the tank wall and should protrude no more than $5 d_j$ from the tank wall. The nozzle should be no more than $5 d_j$ from the tank floor or liquid surface. Axial jets should be installed perpendicular to and no more than $5 d_j$ from the tank floor or liquid surface.

– According to *Revill*,³² if the relative difference between the two liquids to be mixed is in the range $(\rho_2 - \rho_1)/\rho_2 \leq 0.05$, then stratification will not occur. In that case, jet can be placed pointing towards liquid surface or pointing towards tank floor. But if the relative density difference is greater than 0.05, then stratification occurs.

If $\left(\frac{V_1}{V_T}\right) > 0.5$, where V_1 = volume of light liquid, V_T = total batch volume.

Then use upward pointing jet with recycle suction with the recycle suction just beneath the liquid surface. Alternatively if $\left(\frac{V_1}{V_T}\right) < 0.5$, use a downward pointing jet with the recycle suction as near to the tank floor as possible. Though *Revill*³² talked about importance of critical velocity under stratification phenomena, did not mention about critical velocity in his recommendations. Critical velocity is to be considered.

– Section ‘Parameters in jet mixing’ is to be referred for sensitivity analysis of parameters

Recommended design approach

*Revill*³² reported design procedure for jet mixing. Mixing time and pump power requirements are the important design parameters in jet mixing. Tank dimensions, jet configuration i.e. axial jet or side entry jet, angle of side entry jet, jet velocity are the parameters used to calculate mixing time and pump power. Sections ‘parameters in jet mixing’ and recommended jet/tank geometry’ are to be referred in choosing parameters and jet configuration respectively.

Mixing time determination

1. Basing on batch volume decide tank diameter (D) and height (H)
2. Side entry or axial jets should be used basing on the ratio of H/D
3. Calculate the jet path lengths
4. For side entry jets, calculate the angle of inclination of jet.
5. Decide to use downward pointing jet or upward pointing jet and calculate jet velocity based on critical velocity
6. Choose the diameter of jet
7. Now calculate mixing time.

Calculation of power requirement

1. Basing on jet velocity and diameter of jet, calculate jet flow rate
2. Estimate discharge pressure of pump from following relation $p = \Delta p_1 + \Delta p_2 + p_3$, Δp_1 = pressure drop in pipeline from tank take off and jet nozzle, Δp_2 = pressure drop through jet nozzle, p_3 = static pressure of liquid in the tank. Basing on jet flow rate and pressure drop available, calculate pump power requirements.

Computational fluid dynamics (CFD) in jet mixing

In the last two decades or so, computational fluid dynamics (CFD) techniques,^{47–49} which are based on the numerical solution of the governing partial differential equations, have become available to the design engineer in the form of computer codes. These permits the simulation of a variety of flow cases, which can help in assessing various alternative, designs for better performance, and safe operation. CFD is the analysis of systems involving fluid flow, heat transfer and associated phenomena such as chemical reactions by means of computer-based simulation. This technique is powerful and spans a wide range of industrial and non industrial application areas such as mixing and separation in chemical process engineering, aerodynamics of aircraft and vehicles, combustion in internal combustion engines and gas turbines, distribution of pollutants and effluents in environmental engineering, biomedical engineering, meteorology etc applications. Clearly the investment costs of a CFD capability are not small but the total expense is not normally as great as that of high quality experimental facility. There are some unique advantages of CFD over experimental CFD approaches to fluid systems design.

– Ability to study systems where controlled experiments are difficult or impossible to perform (very large systems)

– Ability to study systems under hazardous conditions at and beyond their normal performance limits.

From the literature study it is found that different measurement techniques have been used to determine mixing time in jet mixed tanks. It is one of the reasons for obtaining different correlations for mixing time. All the correlations are case specific and cannot be used for the design of jet mixed tank system. These types of difficulties can be resolved by CFD, because flow variables and concentration everywhere in the tank would be available to verify mixing. CFD involves the numerical solution of complex equations such as Reynolds transport equations, turbulent kinetic energy equation, energy dissipation equation and continuity equation.

So far only few people have investigated jet mixing using CFD. *Brooker*³ studied the performance of jet mixer using CFD and found that CFD model predicts mixing time with a maximum error of 14 % when compared with experimental values. *Souvaliotis et al.*³⁶ investigated errors and limitations of mixing simulations. They identified and examined errors due to discretization, time integration and round off. They concluded that accurate quanti-

tative information could only be obtained from numerical simulations if certain proper steps, such as mesh refinement are taken into consideration. *Hoffman*¹² used FLUENT software package to find whether jet mixer can be used as an effective device for injection of inhibitor into a tank containing monomer. *Jayanti* and *Pavithra*¹⁷ have used CFD code PHOENICS to study the hydrodynamics of dissolution of solids in liquid. They reported that lot of scope exist for CFD simulation for the design of jet mixer. *Ranade*³¹ used CFD code FLUENT for investigating flow pattern using steady and unsteady jets. *Vishwanadhan* and *Jayanti*⁴⁰ used CFD modeling to predict mixing times for side entry and vertical jets. *Unger* et al.³⁸ characterized laminar viscous flow in an impinging jet contactor using CFD and particle image velocimetry (PIV) measurements. They found that mixing is improved substantially if the geometry is made asymmetric. They used FLUENT to obtain agreement between computational and experimental velocity fields. *Cziesla* et al.,⁵ *Gao* and *Voke*¹³ and *Voke* and *Gao*⁴¹ simulated jets impinging on wall using large eddy simulation technique (LES). *Jayanti*¹⁸ used a CFD code CFX to find the optimum shape needed for reduction in mixing time. *Patwardhan*²⁷ compared experimental results with CFD modeling. *Zughbi* and *Rakib*⁴³ presented a CFD model of mixing in a fluid jet agitated tank. They validated their numerical model against the experimental results of *Lane* and *Rice*.¹⁹ Some details regarding validation of nu-

merical model can be found in *Rakib*,³⁰ also. *Zughbi* and *Rakib*⁴⁴ investigated various parameters such as jet angle, position and multiple jets in jet mixed tanks. *Wasewar*⁴⁵ and *Patwardhan* and *Wasewar*⁴⁶ developed in house CFD code to predict the flow field and mixing characteristics in jet mixed tanks. Predicted concentration profile and mixing time have been compared with experimental concentration profile and mixing time. Some of these studies are summarized in Table 2.

Models and methodology

Jayanthi and *Pavithra*¹⁷ used commercial CFD code PHOENICS for the hydrodynamic study of solid distribution in liquid using liquid jet in tank. They used the standard method of discretization, linearization and solution of various transport equation involved in jet mixed tanks. More details can be found in standards text books.^{47–49} Finite volume technique was used to discretized the equations on a staggered grid system and incorporated the SIMPLE algorithm and its variants⁴⁷ for the pressure-velocity decoupling in incompressible flows. $k-\epsilon$ turbulent model was used in which the effect of turbulent diffusion of momentum etc. is represented in terms of two variables, namely, the turbulent kinetic energy per unit mass and its dissipation rate.⁴⁸ They have not presented any validation results. They found that the jets lead to a more uniform distribution of solids in the vessel and that

Table 2 – CFD studies on jet mixing

Author	CFD code	Type of study	Remarks
<i>Brooker</i> ³	Not mentioned	Compared experimental results with CFD	Error of 14 % between experimental and CFD values
<i>Hoffman</i> ¹²	FLUENT	To test injection of inhibitor into tank containing monomer	Jet mixer can be used for injection of inhibitor
<i>Jayanti</i> and <i>Pavithra</i> ¹⁷	PHOENICS	Hydrodynamics of dissolution of solids in liquid.	They suggested that lot of scope exists for CFD simulation
<i>Ranade</i> ³¹	FLUENT	Flow patterns prediction with steady and unsteady jets	Alternating jets give better mixing times
<i>Jayanti</i> ¹⁸	CFX	To find the optimum shape of tank for better mixing	Found that conical bottom is better than hemispherical, ellipsoidal, flat bottom for mixing
<i>Wasewar</i> and <i>Patwardhan</i> ⁴⁶	In house code	Compared experimental results and CFD results	CFD model predicts the overall mixing time well
<i>Patwardhan</i> ²⁷	In house code	Compared experimental results and CFD results	CFD model predicts the overall mixing time well
<i>Rakib</i> and <i>Zughbi</i> ^{43,44}	FLUENT	Investigated effect of jet angle, position of jet, multiple jet in jet mixing	Found that blending is a function of jet angle and position., Multiple jets performance depends on the Reynolds number

is more so in the two-jet case than in the single-jet case. However, in both cases dead zones, where there is little or no recirculation, was existing and the design of the jets needs to be improved

*Jayanthi*¹⁸ used CFX, a commercial CFD code for the study of jet mixing in tank. The equations solved for a CFD solution are the continuity equation and the momentum equation in cylindrical coordinate system. The renormalization group theory (RNG)-based $k-\varepsilon$ turbulence model, in which the additional ‘eddy’ viscosity associated with turbulent flow is calculated in terms of two additional parameters, namely, the turbulent kinetic energy per unit mass and its dissipation rate. The spatial and temporal variation of these quantities within the flow domain was calculated using additional transport equations. Calculations were also made in one case with the standard $k-\varepsilon$ turbulence model. Details of the turbulence models are well known and refer to *Rodi*,⁵⁰ *Anderson et al.*⁴⁸ and *Warasi*⁵¹ for more details of turbulence modeling. Finite volume discretization method on staggered grid arrangement was used. The grid for two-dimensional flow domain consisted typically of 3600–6000 cells. Wall functions were used to calculate the wall parameters in turbulent flow.⁵⁰ The higher upwind differencing scheme, which is second order accurate, was used.⁵²

Wasewar,⁴⁵ *Wasewar* and *Patwardhan*⁴⁶ and *Patwardhan*²⁷ developed in-house CFD code. Reynolds transport equations along with standard $k-\varepsilon$ turbulence model were used to get prediction of mean velocity and turbulence levels throughout the tank. These were used to solve the conservation equation for an inert tracer to get concentration profile and mixing time. The transport equations were discretized by control volume formulation on a staggered grid arrangement. Power-law scheme was used for discretization and SIMPLER algorithm of *Patankar*⁴⁷ was used. The discretized equations were solved by TDMA algorithm to obtain the velocity, pressure and turbulence fields. Specifying the number of grids occupied by the nozzle simulated the jet entry into the tank

Zughbi and *Rakib*⁴⁴ used FLUENT CFD code to investigate the effects of jet angle and elevation on mixing in a jet mixed tank. Finite volume approximations were used to solve the governing transport equations. A total 46 839 cells were used to mesh the tank. The equations were solved using a pressure-implicit with splitting of operators (PISO) pressure-velocity coupling scheme, which is a part of the semi-implicit method for pressure-linked equations (SIMPLE) family algorithm. PISO is based on a higher degree of the approximate relation between the corrections for pressure and velocity. PISO improves the efficiency of the

calculations when compared to SIMPLE or SIMPLER, by performing additional corrections, namely neighbor correction and skewness correction. Neighbor correction can be summarized as moving the repeated calculations required by SIMPLE inside the solution stage of the pressure correction equation. PISO is recommended for transient calculations (FLUENT Manual⁵³). Standard $k-\varepsilon$ turbulence model was used. More sophisticated turbulence models, such as the Reynolds stress model (RSM), were also tried but gave almost identical results (>1 % difference in the final value of mixing time) as the $k-\varepsilon$ model, but the computational time needed was about three times larger.⁴⁴

*Ranade*³¹ investigated the flow patterns and mixing in jet agitated vessel using commercial CFD code FLUENT. Standard $k-\varepsilon$ turbulence model was used. A total 60648 computational cells were used.

Validation of CFD model

It is always necessary to validate the calculation methodology by comparing with experimental/analytical results specific to the phenomena under consideration. In jet mixed tanks, the predicted results should be compared with existing results for jet mixed tanks to demonstrate the accuracy of the simulations.

*Jayanti*¹⁸ used CFX commercial CFD code for the study of jet mixed tank. The validation was carried out in three steps. Results were compared with the analytical results given in *Schlichting*³⁴ and *White*⁷². It was observed that the calculated velocity profiles at various axial distances, after non-dimensionalization, collapse on to a single curve and that this curve agrees very well with the theoretical one. CFD simulations were compared with that predicted by correlation of *Fox* and *Gex*.¹¹ The good agreement between the two suggested that a $Re^{-1/6}U_j^{-0.67}$ variation was consistent with the CFD results. Also the CFD results were compared with the experimental data of *Simon* and *Fonade*³⁵ and *Orfanotis et al.*²⁶ The absence of sharp peaks in CFD prediction for mixing time profile (tracer concentration), as compared to experimental results, was observed. These may be caused by turbulent fluctuations, which are ‘averaged-out’ in a CFD framework; ensemble averaging a number of such tracer responses would be a better experimental measure, which can be compared with the CFD prediction.¹⁸ One quantitative feature that can be compared between the experiments and the simulations is the overall mixing time. The CFD predicted overall mixing time was in good agreement with experimental overall mixing time of *Simon* and *Fonade*³⁵ and *Orfanotis et al.*²⁶ and was within ± 5 margin.

*Patwardhan*²⁷ compared CFD predicted mixing time with experimental results for various nozzle angles and at various jet locations using in-house developed code. CFD model underpredicted the mixing time by 5–30 % for 30 and 60 degree nozzles, overpredicts by 15 % for 90 degree nozzle, and good agreement for 45 degree. For concentration profile comparison, CFD model predicted the rise of concentration faster than that observed experimentally and the final mixing time predictions were reasonably good. *Patwardhan*²⁷ has given the excellent explanation for these comparisons. The experimentally observed circulation times are longer than CFD predictions and the decay of peak value of concentration profiles is faster in actual experiments than those predicted by CFD. These depict the underprediction of the extent of turbulent dispersion. This is due to an underprediction of the turbulent kinetic energy, which is responsible for the underprediction of eddy diffusivity. One way of improving the prediction of turbulent quantities would be to specify the values of turbulent kinetic energy as boundary conditions at the jet entry to the tank. It was observed, that specifying turbulent intensity to be 10 %, gives better prediction of concentration profiles as compared to other simulations.

Zughbi and Rakib^{43,44} compared FLUENT CFD code predicted mixing times as a function on Reynolds number with mixing time measured by *Lane and Rice*.¹⁹ A good agreement was observed between the experimental results and the simulation results.

Effect of jet location

*Jayanti and Pavithra*¹⁷ used location of jets as one of the parameters in their work. They suggested that CFD simulations could be extended to give proper choice of the position of the jet. *Zughbi and Rakib*⁴⁴ positioned jet at various heights in a constant geometry. They found that position of jet could also affect mixing time. This fact is to be taken into consideration in the design of jet mixing.

Effect of angle of injection

*Zughbi and Rakib*⁴⁴ found that for a fixed height of a liquid in a tank, varying the angle of the jet will affect not only the effective mixing length of the jet, but also the overall flow patterns inside the tank, which is the key factor in deciding the overall blending time. This finding contradicts with the theory of *Okita and Oyama*.²⁵ The optimum angle of injection was found to be 30° for the geometry of *Lane and Rice*.¹⁹ This finding contradicts with earlier studies that angle of injection at 45° gives smallest blending time. This numerical work of *Zughbi and Rakib*⁴⁴ co-

incided with that of *Maruyama*^{23,65,66} and *Patwardhan*²⁷ also tried to study the effect of angle of jet on mixing time using CFD.

Effect of multiple jets

*Hoffman et al*¹² studied jet mixing using two opposite jets with CFD code. *Jayanti and Pavithra*¹⁷ concluded that jet mixing with single jet leads to uniform distribution of solids in solution and this is more so in two jet case than in the single jet case. *Zughbi and Rakib*⁴⁴ have used CFD for seeing the effect on mixing time with two opposing jets. For the same value of the jet Reynolds number, a lower blending time for two opposing jets was predicted compared to that, when a single jet was used. Single jet has 45 % higher blending time for jet Reynolds number of 6 660, and 68 % higher blending time for a jet Reynolds number of 2500, as compared to two opposing jets. At very high Reynolds number, the differences in blending times for these two geometries become smaller. So Reynolds number plays a crucial role with multiple jets performance.

Effect of shape of geometry

*Jayanti*¹⁸ has tried to find the optimum shape of the bottom for cylindrical vessel. The shapes of bottoms considered in his experiments are hemispherical base, ellipsoidal base, conical base with half cone angles of 31° and 58°. *Jayanti*¹⁸ found better mixing times and velocity field for bottoms with conical shape.

Effect of Reynolds number

Though *Zughbi and Rakib*⁴⁴ did not explicitly mention the range of Reynolds number used, they concluded that at very high Reynolds number, there was not much difference with single and double jets on the mixing times. So the range of Reynolds number is very vital role in jet mixing.

Effect of calculation scheme

*Patwardhan*²⁷ changed the parameters in the standard *k-ε* model and saw its effect on the mixing behavior of the jets. *Zughbi and Rakib*⁴⁴ used standard turbulence *k-ε* model and RNG *k-ε* model. The difference is not very remarkable and overall predicted mixing time is affected only by 5 % more with standard *k-ε* model. Though, slight better results are obtained for RNG *k-ε* model, computation time required is far more than standard *k-ε* model. So standard *k-ε* model can be used as a calculation scheme.

Effect of injection period

*Jayanti*¹⁸ has done simulation experiments with injection periods of 1 and 10 seconds. It was con-

cluded that injection period and tracer concentrations do not affect the mixing time as long as they are reasonably small.

Conclusion

Mixing is one of the most important unit operations in the chemical industries. Jet mixing is an alternative of mechanical agitators especially for large and underground storage tanks. This paper explains briefly about jet mixing process and various experimental studies and its limitations conducted on jet mixing. It also explains the need of review on jet mixing. Many experimental correlations are available in the literature. The only comprehensive study is given by *Grenville and Tilton*.^{14,15} So, the correlation proposed by them can be used with more confidence than any other correlation. Various parameters studied by many people on jet mixing have been identified and their effects on mixing time are described in this review. Tank geometry (height, diameter), jet configuration (side entry jets, vertical jets etc, number of jets), jet velocity, jet diameter, jet flow rate and fluid properties, such as viscosity are some of the parameters affecting mixing time. Recommendations and design procedure given by *Revill*³² and *Bathija*² for jet mixing are presented. CFD studies on jet mixing have been covered. It is found that lot of scope exists for CFD in design of jet mixing.

Notation

A	– cross sectional area, m^2
c	– concentration at anytime, $kmol\ m^{-3}$
c_j	– concentration at jet, $k\ mol/m^{-3}$
\bar{c}	– mean or reference concentration, $k\ mol\ m^{-3}$
c_c	– centerline concentration, $k\ mol\ m^{-3}$
c^*	– degree of mixing
C_p	– correlation constant (<i>Fossett and Prosser</i> , 1949)
D	– diameter of the tank, m
d_j	– diameter of jet, m
f	– mixing time factor for the correlation of <i>Fox and Gex</i> ¹¹ and <i>Lane and Rice</i> ¹⁹
g	– acceleration due to gravity, $m\ s^{-2}$
H	– height of liquid or tank height, m
h_i	– nozzle height from bottom of the tank, m
h_o	– outlet height from bottom of the tank, m
E	– excessive head in Fossett correlation for critical velocity, ft
J	– momentum of jet, $kg\ m\ s^{-2}$
J_s	– specific jet momentum, dimensionless
k	– correlation constant for the correlation of <i>Grenville and Tilton</i> ^{14,15}

K_c	– correlation constant in <i>Grenville and Tilton</i> ^{14,15}
L	– jet path length, m
m	– dimensionless quantity, maximum deviation from ideal mixing
M	– mixing factor in <i>Simon and Fonade</i> ³⁵ correlation
N_j	– Number of jets
p	– Discharge pressure, Pa
Q_e	– entrainment flow rate, $m^3\ s^{-1}$
Q_G	– total flow rate through nozzle in <i>Fossett</i> correlation ^{9,8} for critical velocity, gallons per hour (1 gal = 3.18541 dm^3)
Q_T	– flow rate at distance Z from jet, $m^3\ s^{-1}$
Q_0	– flow rate at the orifice, $m^3\ s^{-1}$
R_j	– radius of the expanding jet, m
r	– perpendicular distance from the jet, m
Re_j	– jet Reynolds number
t_r	– residence time, s
t_{inj}	– time for injection of tracer, s
t_{mix}	– mixing time, s
V_1	– volume of light fluid
v_c	– critical velocity, $m\ s^{-1}$
v_j	– jet velocity, $m\ s^{-1}$
v_m	– centerline jet velocity, s^{-1}
V_T	– Total batch volume, m^3
z	– distance from the jet in the direction of the jet flow, m

Greek letters

ε	– turbulent energy dissipation rate, $m^2\ s^{-1}$
μ	– molecular viscosity, $kg\ m^{-1}\ s^{-1}$
θ	– jet angle, $^\circ$
ρ_j	– jet fluid density, $kg\ m^{-3}$

References

- Baldyga, J., Bourne, J. R., Zimmermann, B.*, *Chem. Eng. Sci.* **49**(12) (1994) 1937.
- Bathija, P. R.*, *Chem. Eng.* **2** (1982) 89.
- Brooker, L.*, *Chem. Eng.* **30** (1993) 16.
- Coldrey, P. W.*, Paper to I.Chem.E.Course, Univ. of Bradford, England, July, (1978).
- Cziesla, T., Biswas, G., Chattopadhyay, H., Mitra, N. K.*, *Int. J. of Heat and Fluid Flow* **22** (1982) 500.
- Davies, J. T.*, *Turbulence phenomena*, Academic Press, New York, (1972).
- Donald, M. B., Singer, H.*, *Tran. Inst. Chem. Engrs* **37** (1959) 255.
- Fossett, H., Prosser, L. E.*, *Proc. Inst. Mech. Eng.* **160** (1949) 224.
- Fossett, H.*, *Mech. E, M. I.*, *Tran. Inst. Chem. Engrs.* **29** (1951) 322.
- Folsom, G., Ferguson, C. K.*, *Tran. American. Soc. Mech. Eng.* **71** (1949) 73.
- Fox, E. A., Gex, V. E.*, *AIChE J.* **2** (1956) 539.
- Hoffman, P. D.*, *AIChE Symposium series no. 286*, **88** (1996) 77.

13. Gao, S., Voke, P. R., *Int. J. of Heat and Fluid Flow* **16** (1995) 349.
14. Grenville, R. K., Tilton, J. N., *Tran. Inst. of Chem. Engrs.* **74A** (1996) 390.
15. Grenville, R. K., Tilton, J. N., *Progress en Genie des Procedes* **11(51)** (1997) 67.
16. Hiby, J. W., Modigell, M., 6th CHISA congress, Prague (1978).
17. Jayanti, S., Pavithra, J., *Proc. of the Int. Conf. on Advances in Chemical Engineering, Madras, India* (1996) 125.
18. Jayanti, S., *Chem. Eng. Sci.*, **56** (2001) 193.
19. Lane, A. G. C., Rice, P., *Tran. of the Inst. of Chem. Engrs* **60** (1982) 171.
20. Lehrer, H., *Tran. of the Inst. of Chem. Engrs.* **59** (1981) 247.
21. Lee, L. J., Ottino, J. M., W. E., Macoska, C. W., *Polymer Eng. Sci.* **20** (1980) 868.
22. Lane, A. G. C., Rice, P., *Ind. Chemistry Eng. Symposium Series No. 64.* (1981) K1.
23. Maruyama, T., Ban, Y., Mizushina, T., *J. Chem. Eng. Jpn.* **15** (1982.) 342.
24. Mewes, D., Renz, R., 7th European Conference on mixing, Kiav, Brugge, Sept 18–20, Belgium, 1991, 131.
25. Okita, N., Oyama, Y., *Japanese Journal of Chemical Engineers* **31(9)** (1963) 92.
26. Orfaniotis, A., Fonade, C., Lalane, M., Doubrovine, N., *Can. J. Chem. Eng.* **5** (1996) 203.
27. Patwardhan, A. W., *Chem. Eng. Sci.* **57** (2002) 1307.
28. Patwardhan, A. W., Gaikwad, S.G. *Tran. Inst. Chem. Eng.* **81A** (2003) 211.
29. Perona, J. J., Hylton, T. D., Youngblood, E. L., Cummins, R. L., *Ind. Eng. Chem. Res.* **38** (1998) 1478.
30. Rakib, M. A., M. Sc. Thesis, King Fahd University of petroleum & Minerals (2000).
31. Ranade, V. V., *Chem. Eng. Sci.* **51** (1996) 2637.
32. Revill, B. K., in *Mixing In Process Industries*, Harnby, N., Edwards, M. F., Nienow, A. W. (eds) 2nd edn chapter 9 (Butterworth-Heinemann, Oxford, UK) 1992, 159.
33. Schimetzek, R., Steiff, A., Weinspach, P. M., *Proc. of 8th European Conf. on Mixing* 136 (1994) 391.
34. Schlichting, H., *Boundary layer theory*, 6th edition, McGraw-Hill Book Company, New York, USA 1968.
35. Simon, M., Fonade, C. *Can. J. Chem. Eng.* **71** (1993) 507.
36. Souvaliotis, A., Jana, S. C., Ottino, J. M., *AIChE J.* **41** (1995) 1605.
37. Voke P R and Gao S., *Int. J of Heat and Fluid Flow*, **41** (1998) 671.
38. Unger, D. R., Muzzio, F. J., Brodkey, R. S., *Can. J. Chem. Eng.* **76** (1998) 546.
39. Van de Vusse, J. G., *Chemie. Ing. Tech.* **31** (1959) 583.
40. Vishwanadh, V., Jayanti, S., *Proc. of the third Asian CFD Conf. Vol II December 7–11, Bangalore, India 1998*, pp.92–97.
41. Voke, P. R., Gao, S., *Int. J. of Heat and Mass Transfer* **41** (1998) 671.
42. Yianneskis, M., 7th European Conf. on Mixing, Kiav, Brugge, Sept 18–20, Belgium, (1991) 121.
43. Zughbi, H. D., Rakib, M. A., *Chem. Eng. Comm.* **189** (2002) 1038.
44. Zughbi, H. D., Rakib, M. A. *Chem. Eng. Sci.* **59** (2004) 829.
45. Wasewar, K. L., *Modeling of jet mixed tanks*, M. Chem. Engg. Thesis, UDCT, Mumbai, India. (2000).
46. Wasewar, K. L., Patwardhan, A. W., *National Conference on Mathematical Modeling and Analysis, BITS, Pilani-333031, INDIA, Oct.8–9, (2004).*
47. Patankar, S. V., *Numerical heat transfer and fluid flow*, Hemisphere, Washington (1980).
48. Anderson, D. A., Tannhill, J. C., Pletcher, R. H., *Computational fluid mechanics and heat transfer*, Hemisphere, Washington 1984.
49. Hirsch, C., *Numerical Computation of internal and external flows*, vol I & II, Wiley, New York (1988).
50. Rodi, W., *Turbulence models and their applications in hydraulics: a state of the art review*, Presented by the IAHR Section on fundamentals, Division II: experimental and mathematical fluid dynamics 2nd Edn. (1984).
51. Warasi, Z. U., *A Fluid dynamics: theoretical and computational approaches*. Baton Rouge, USA: CRC Press (1993).
52. Alderton, J. H., Wilkes, N. S., *Some applications of new finite difference schemes for fluid flow problems*, UK AEA Report No. AERE-R1324, 1988.
53. FLUENT Manuals, Fluent Inc., Lebanon, NH, USA, 1998.
54. Wood, P., Hrymak, A., Yeo, R., Johnson, D., Tyagi, A., *Physics of fluids A* **3** (1991) 1362.
55. Cziesla, T., Biswas, G., Chattopadhyay, H., Mitra, N. K., *Int. J of Heat and Fluid Flow*, **22** (2001), 500.
56. Gao, S., Voke, P. R., *Int. J of Heat and Fluid Flow*, **16** (1995) 349.
57. Sarsten, J. A., *Pipeline and Gas J.* Sept. 37–39 (1972).
58. Sudhindra, N., Sinha, S. N., Paper C4, 4th Europ. Conf. On Mixing, Leeuweenhorst, Netherlands (27–29 April) (1982).
59. Abramovich, G. N., *The theory of turbulent jets*, MIT Press (1963).
60. Rajaratnam, N., *Turbulent Jets*, Elsevier Scientific Publ. Co. (1976).
61. Racz, I., Wassink, J. G., *Chem. Eng. Tech.* **46** (1974) 261
62. Fackler, R., *Proc. 5th Euro. Conf. On Mixing*, Wurzburg, Germany, BHRA Fluid Eng., Crnafield, England, (1985) 541.
63. Hiraoka, S., Tada, Y., Yamada, I., Takahashi, T., Koh, S. T., *Proc. SCEJ-CICHe Joint Seminar on Mixing technology*, edited by W-L Lu, Taipei, Taiwan, July 14–15, (1987).
64. Coker, A., K., Jeffreys, G. V., *Fluid Mixing III*, I. Chem. Eng. Sym. Ser. No. 108,105, (1988).
65. Maruyama, T., *Jet mixing of fluids in vessels*. In N P Chermesinoff, *Encyclopedia of fluid mechanics*. Vol 2. chapter 2, Gulf Publishing Company, Houston, TX, 1986, pp. 544–562.
66. Maruyama, T., Kamishima, N., Mizushina, T., *J. Chem. Eng. Japan*, **17**, (1984) 20.
67. Rice, P., *Batchwise jet mixing in tanks IN: Chermesinoff, Encyclopedia of fluid mechanics*, Houston, USA, Gulf Publishing Co. Chapter 18 (1986).
68. Lane, A. G. C., Rice, P., *Tran. of the Inst. of Chem. Engrs* **60** (1982) 245.
69. Lane, A. G. C., Rice, P., *Poster v, 4th European Conf. On Mixing*, Leeuweenhorst, Netherlands 27–29 April 1982.
70. Lane, A. G. C., *Ph.D. Thesis*, Loughborough Univ. of Tech. 1982.
71. Revill, B. K., *Paper to I. Chem. E., Mixing in the process Industries*, course, Bradford University, UK July 1981.
72. White, F. M., *Viscous fluid flow*. New York MacGraw-Hill 1974.